

Mess-, Regel- und
Überwachungsgeräte
für Haustechnik,
Industrie und Umweltschutz

Lindenstraße 20
DE-74363 Güglingen
Telefon: +49(0)7135-102-0
Service: +49(0)7135-102-211
Telefax: +49(0)7135-102-147
E-Mail: info@afriso.de
Internet: www.afriso.de





Instruction Manual

Automatic Fuel Oil De-aerator Flow-Control

Flow-Control 3/K-1
Flow-Control 3/K-2

69942
70019



-  Read manual before use!
-  Observe all safety information!
-  Keep manual for future use!

Contents

1	About this instruction manual.....	3
1.1	Structure of warning	3
1.2	Explanation of symbols and typeface.....	3
2	Safety.....	4
2.1	Intended use	4
2.2	Predictable incorrect application	4
2.3	Safe handling.....	4
2.4	Qualification of personnel.....	4
2.5	Modifications to the product.....	5
2.6	Use of spare parts and accessories	5
2.7	Liability information.....	5
3	Product description	5
3.1	Function.....	6
3.2	Application examples.....	7
4	Specifications.....	8
4.1	Approvals, tests and conformities	8
5	Installation and commissioning.....	8
5.1	Right dimension of the suction tube	9
5.2	Pressure test	10
5.3	Parallel connection	10
6	Troubleshooting	11
7	Spare parts and accessories	11
8	Warranty	12
9	Copyright.....	12
10	Customer satisfaction	12
11	Addresses	12



1 About this instruction manual

This instruction manual is part of the product.

- ▶ Read this manual before using the product.
- ▶ Keep this manual during the entire service life of the product and always have it readily available for reference.
- ▶ Always hand this manual over to future owners or users of the product.

1.1 Structure of warning

WARNING TERM The type and source of danger is shown here.



- ▶ Precautions to take in order to avoid the danger are shown here.

There are three different levels of warning:

Warning term	Meaning
DANGER	Imminent danger! Failure to observe the information will result in death or serious injuries.
WARNING	Possible imminent danger! Failure to observe the information may result in death or serious injuries.
CAUTION	Dangerous situation! Failure to observe the information may result in minor or serious injuries as well as damage to property.

1.2 Explanation of symbols and typeface

Symbol	Meaning
<input checked="" type="checkbox"/>	Prerequisite for an activity
▶	Activity consisting of a single step
1.	Activity consisting of several steps
↪	Result of an activity
•	Bulleted list
Text	Indication on a display
Highlighting	Highlighting



2 Safety

2.1 Intended use

The automatic fuel oil de-aerator Flow-Control may only be used in single-line systems with return pipe connection for continuous de-aeration of the following liquids in oil-fired systems:

Liquid	Flow-Control 3/K-1	Flow-Control 3/K-2
Light fuel oil EL according to DIN 51603-1	X	X
Diesel according to EN 590	X	X
Fuel oil with 0-20 % fatty acid methyl ester (FAME) according to EN 14213	X	X
Fuel oil with 0-100 % fatty acid methyl ester (FAME) according to EN 14213	–	X

Any use other than the use explicitly stated in this instruction manual is not permitted.

2.2 Predictable incorrect application

The automatic fuel oil de-aerator Flow-Control must never be used in the following:

- Use with undissolved additives, alcohols and acids

2.3 Safe handling

The automatic fuel oil de-aerator Flow-Control represents state-of-the-art technology and is manufactured in accordance with the pertinent safety regulations. Each unit is subjected to a function and safety test prior to despatch.

- ▶ Operate the automatic fuel oil de-aerator Flow-Control only when it is in perfect condition. Always observe the instruction manual, all pertinent local and national directives and guidelines as well as health and safety regulations and directives regarding the prevention of accidents.

2.4 Qualification of personnel

The product may only be installed, commissioned, operated, maintained, shut down and disposed of by qualified, specially trained personnel.

Law or building codes may require an inspection by local or federal authorities.

2.5 Modifications to the product

Changes or modifications made to the product by unauthorised persons may lead to malfunctions and are prohibited for safety reasons.

2.6 Use of spare parts and accessories

Use of unsuitable spare parts and accessories may cause damage to the product.

- ▶ Use only the manufacturer's genuine spare parts and accessories (refer to chapter 7, page 11).

2.7 Liability information

The manufacturer shall not be liable for any direct or consequential damage resulting from failure to observe the technical instructions, guidelines and recommendations.

The manufacturer and the sales company shall not be liable for costs or damages incurred by the user or by third parties in the use or application of this device, particularly in case of improper use of the device, misuse or malfunction of the connection, malfunction of the device or of connected devices. The manufacturer or the sales company shall not be liable for damages resulting from any use other than the use explicitly stated in this instruction manual.

The manufacturer shall not be liable for misprints.

3 Product description

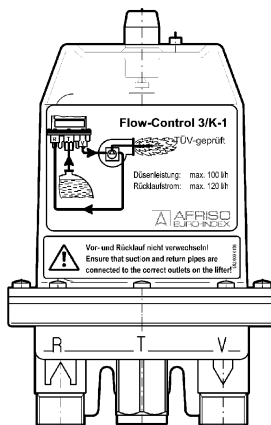

Fig. 1: Flow-Control 3/K-1

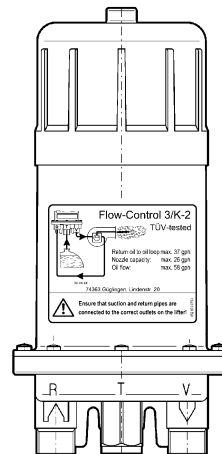

Fig. 2: Flow-Control 3/K-2

Flow-Control 3/K-1 consists of a diecast zinc housing with a connection thread at the tank side and connection threads for connec-

tion of the burner hoses. The float chamber is made of transparent plastic.

Flow-Control 3/K-2 is equipped with two separate float chambers. The first float chamber consists of a de-aerator hood with operating and de-aerating float. The second one is a safety float chamber. It prevents the oil foam from escaping via the de-aerator opening (e.g. during commissioning/filter exchange) and indicates malfunctions of the de-aerator valve. The float chambers are made of transparent plastic.

3.1 Function

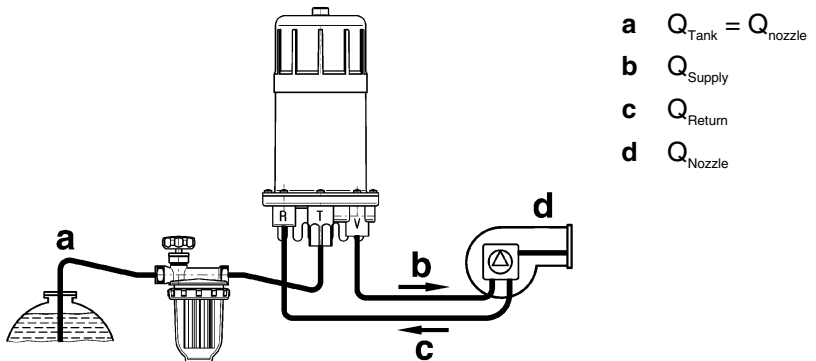

Fig. 3: Flow-Control 3/K-2 with filter

The burner pump draws the fuel oil from the tank via the filter and the non-return valve installed in Flow-Control and delivers it to the nozzle. The excess oil (i.e. the oil exceeding the nozzle capacity) is pumped into the float chamber via the return pipe. While the oil level gradually increases in the float chamber, the oil is de-aerated by the de-aeration valve.

When the oil reaches a level of approx. 1 3/16" above the bottom, the floats begin to operate and actuate the bypass valve, thus delivering the de-aerated return oil to the suction pipe.

This way, the system only withdraws the amount of oil from the tank via the filter which is actually needed for combustion. This considerably prolongs the filter service life. The maximum possible service life can be obtained with the long filter insert made of sintered plastic (Optimum).

The oil that now flows to the pump primarily consists of de-aerated fuel oil plus oil from the tank that still contains air.



3.2 Application examples

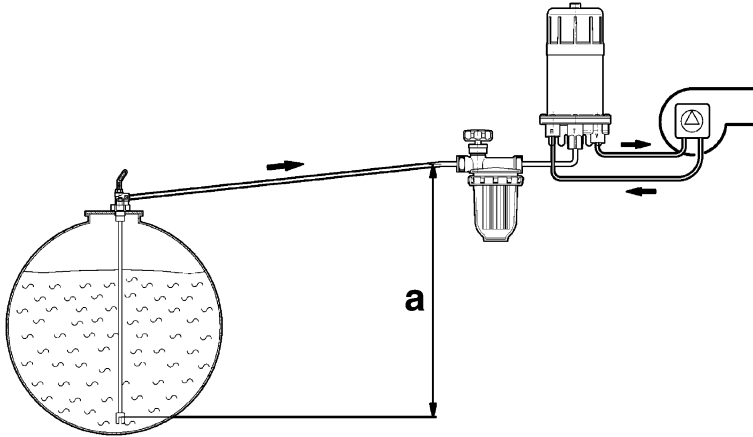

a Max. 15 ft

Fig. 4: Installation of Flow-Control 3/K-2 above the tank level with self-securing suction pipe (steady gradient to the tank). The non-return valves in the withdrawal fitting or at the end of the suction hose must be removed.

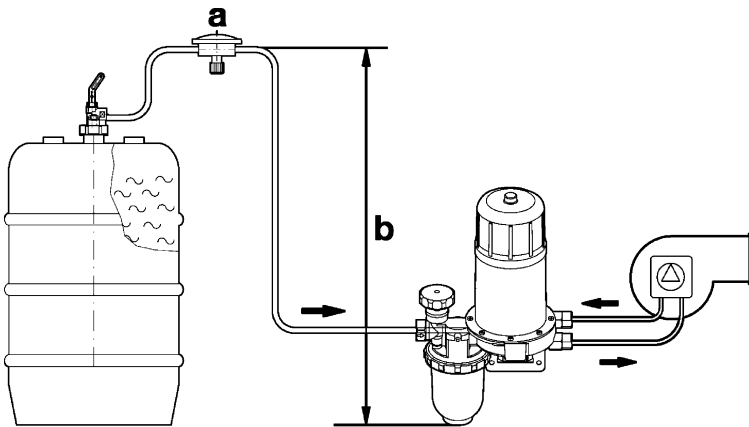

- a Diaphragm anti-siphon valve
- b Static pre-pressure for sizing the anti-siphon valve

Fig. 5: Installation of Flow-Control below the tank level. It is recommended to install a diaphragm anti-siphon valve or an oil safety valve to prevent fuel oil from escaping in the case of a defective suction line with a higher oil level in the tank. In case of fire, the valve will prevent oil from running out and intensifying the fire.



4 Specifications

Table 1: Specifications

Parameter	Value
General specifications	
Dimensions: (W x H x D)	
Flow-Control 3/K-1	3.74" x 5.90" x 3.74"
Flow-Control 3/K-2	3.74" x 7.87" x 3.74"
Burner connection	¼-NPZ inner thread 
Tank connection	¼-NPZ inner thread
Nozzle capacity	Max. 26 gph
Return flow	Max. 37 gph
Oil flow	Max. 58 gph
Separation capacity air/gas	Up to 4 l/h
Mounting position	Float housing vertical to the top
Operating overpressure	Max. 10 psi
Suction vacuum	Max. 7.5 psi
Test pressure	Max. 85 psi
Operating temperature range	
Ambient	Max. 140 °F (60 °C)
Operation	Max. 140 °F (60 °C)

4.1 Approvals, tests and conformities

Flow-Control is TÜV-tested, report no. V132 2007 V1.

5 Installation and commissioning

- ▶ Install Flow-Control between the burner and the shut-off valve, close to the oil burner.
- ▶ Never use Flow-Control in ambient temperatures greater than 140 °F. Do not mount the product in the vicinity of uninsulated burners, over burner opening flaps or next to chimney flues.
- ▶ Mount the float chamber vertically, pointing to the top, so it fits securely and cannot come loose..
- ▶ Use oil hoses as per local codes for connection to the oil pump.



- ▶ Ensure that the pump is set for two-pipe operation when mounting the product. Bypass plug must be installed.
- ▶ Install an oil filter in the supply line in order to protect Flow-Control.
- ▶ A 3/8" pipe is sufficient for most installations. In larger systems requiring 1/2" pipes (if the consumption is less than 5 1/4 gph), all parts of the pipes leading upwards should be calculated as suction height. If the suction pipes are larger than 1/2", this should be taken into consideration as well (even if the consumption amounts to more than 5 1/4 gph). Large pipes with low flow rates may cause gas accumulations, resulting in insufficient suction in the downward sections.
- ▶ Mount Flow-Control as shown in fig. 3, page 6.
- ▶ Remove all check valves between Flow-Control and tank.
- ▶ Never install a shut-off valve or other device, which can impede flow in the lines between the oil de-aerator and the oil pump.
- ▶ All pipework must be tested during installation.
- ▶ Never use Flow-Control with pump pressure between tank and Flow-Control.
- ▶ Test the completed installation for correct function and fire security before starting.
- ▶ Only one fuel unit per Flow-Control connection.

CAUTION

Damage to the pump or Flow-Control due to incorrect connection of supply and return connections.

- ▶ Do not confuse the supply and return connections (not even during commissioning for a short period of time).

5.1 Right dimension of the suction tube

Table 2: Standard values for tube dimensioning

Volume flow in the suction tube	Tubing size copper
0-13 gph	5/16"
8-24 gph	3/8"
18-37 gph	1/2"

5.2 Pressure test

When subjecting the suction pipe to a pressure test, the pressure connection must not be made at the Flow-Control unit since the non-return valve integrated in the device does not allow the pressure to be applied to the suction pipe. Therefore, the device is not to be included in the pressure test.

5.3 Parallel connection

The built-in check valve permits connection of several oil burners to the same feed line. In this case, the total oil consumption must be used when calculating this pipe resistance. For larger capacities, two or more Flow-Control can be connected in parallel.

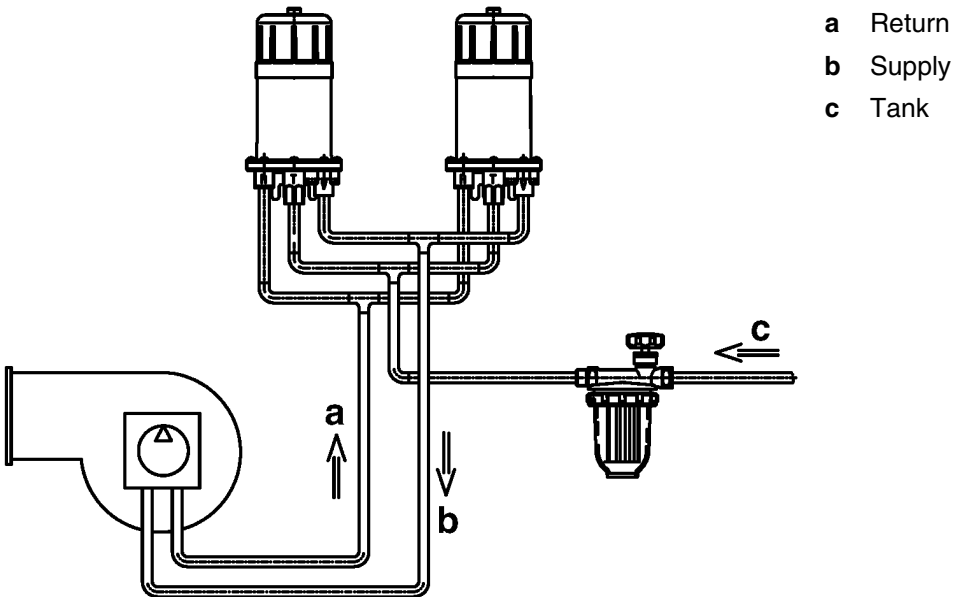

Fig. 6: Parallel operation of two Flow-Control 3/K-2 units



6 Troubleshooting

Table 3: Troubleshooting

Problem	Possible reason	Remedy
Oil foam: The amount of air sucked into the de-aerator exceeds the separating capacity of the device (4 l/h). Note: In single-pipe mode, only the amount consumed by the burner is transported through the suction pipe.	Leak in the suction pipe.	▶ Check the suction pipe for leaks.
	Initial commissioning (without separate suction pump).	▶ Use a suction pump for the commissioning.
	Suction pipe dimensions too great.	▶ Refer to chapter 5.1, page 9.
Flow-Control is completely filled with oil.	Pressure in the feed line (tank higher than burner). This won't affect the function of the pump.	▶ Install an oil safety valve on the feed line from the tank. The oil level will resume its normal level in the Flow-Control.

7 Spare parts and accessories

To prevent odours from the separated air (e.g. if the unit is installed in kitchens), a vent hose can be connected to the Flow-Control hood.

Part	Part no.
Vent hose, PA, 4 x 1 mm, roll of 50 m	820 030 0410
Flow-Control 3/K-1 only:	
Vent nipple with O ring Ø 12 x 2.5 mm and hose connection G 3/8 x 4 mm	69940

1. Flow-Control 3/K-1 only: Screw in the vent connection with a spanner size 19 until the O ring presses against the flat surface of the hood.
2. Push the vent hose onto the vent nipple and route it to the tank next to the suction pipe.
3. Fixate the vent hose with cable straps.
4. Mount the other end of the vent hose to the de-aeration pipe or the return connection of the withdrawal fitting at the tank to prevent clogging.



5. Use the enclosed hose connection for connection to the return connection of the withdrawal fitting.



Bild 7: Flow-Control 3/K-1

Bild 8: Flow-Control 3/K-2

8 Warranty

The manufacturer's warranty for this product is 24 months from date of purchase. This warranty applies to all countries in which this product is sold by the manufacturer or its authorised representatives.

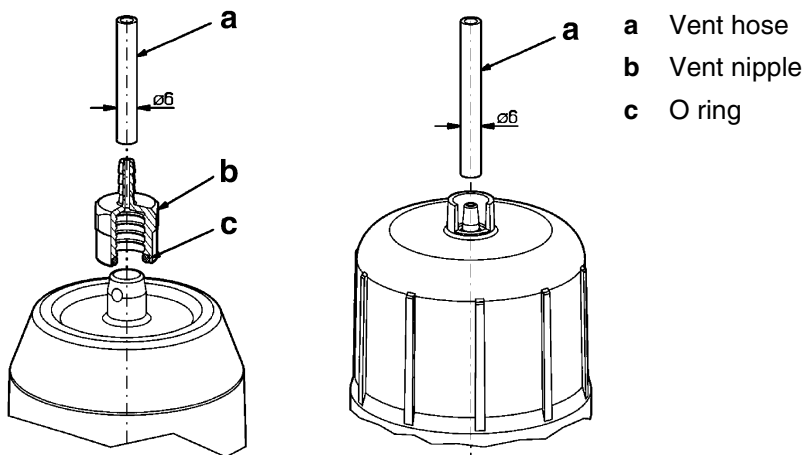
9 Copyright

The manufacturer holds the copyright to this manual. This manual may only be reprinted, translated, copied in part or in whole with the prior written consent of the manufacturer.

We reserve the right to modify any specifications or alter any illustrations in this manual without prior notice.

10 Customer satisfaction

Customer satisfaction is our prime objective. Please get in touch with us if you have any questions, suggestions or problems regarding your product.

11 Addresses

The addresses of our worldwide representations can be found on the Internet at www.afriso.de.